

Debugging Serial Bus Systems with a Mixed-Signal Oscilloscope

Application Note 1395

Who Should Read This Application Note?

This application note is for digital designers in R&D working with both analog and digital components, including microcontroller and DSP systems using serial buses. This application note discusses the challenges associated with and new solutions for debugging serial bus designs including a Controller Area Network (CAN), Inter Integrated Circuit (I²C), Serial Peripheral Interface (SPI), or Universal Serial Bus (USB).

Introduction to Serial Bus Protocols

For many years, parallel buses have been the primary method for communicating with peripheral devices in microcontroller and DSP-based designs. Microcontrollers and DSPs are used in many types of applications from consumer products, such as a cell phone, to control of the electrical system in a car, to many different types of embedded systems including industrial applications. In these types of applications, bus speeds typically operate in the tens of megahertz and below range. Because these applications continue to grow in complexity

while trying to maintain minimal costs, serial buses are commonly used as the method for communicating between devices and peripherals. In addition to a lower cost contribution, serial bus designs use less power, and fewer pins and therefore require less board space.

Serial buses allow for the transmission of data over a serial line with a minimal amount of control lines and connections. Today, there are a large number of devices designed with serial protocol interfaces by many manufacturers. These buses are widely used for interfacing microcontrollers and DSPs to EEPROMs, analog to digital converters, sensors, actuators, and many other peripherals. These systems are often used as control buses and networks inside TV equipment, cellular phones, automobiles, and in many other industrial applications.

The major advantage of using a serial bus is the small number of signals required. A disadvantage of serial interfacing is the trade-off of speed for space in the design. The microcontroller's I/O port can spend a significant amount of time communicating with a serial device. Another disadvantage of using a serial bus in

a mixed analog and digital design is in debugging problems in the system. The difficulty lies in extracting information about the protocol itself and in determining the interactions between devices from a long serial stream of data.

Table of Contents

Introduction to Serial Bus Protocols . . .	1
Debugging Serial Bus Systems with a Mixed-Signal Oscilloscope (MSO) . . .	2
Inter-Integrated Circuit (I²C)	
Introduction	4
Debugging an I²C Bus System with the MSO Triggering Features	5
Serial Peripheral Interface (SPI)	
Introduction	8
Debugging an SPI Bus System with the MSO Triggering Features	9
Controller Area Network (CAN)	
Introduction	10
Debugging a CAN Bus System with the MSO Triggering Features	12
Universal Serial Bus (USB)	
Introduction	14
Debugging a USB System with Agilent MSO Triggering Features	15
Summary	17
Information on Agilent MegaZoom and Mixed-Signal Oscilloscopes	18
Support, Services, and Assistance	19



Debugging Serial Bus Systems with a Mixed-Signal Oscilloscope

There are different types of measurement problems encountered when debugging mixed analog and digital serial bus designs. Designers may need to debug the behavior of the serial bus protocol itself or they may be using an established serial protocol connection to get an entire design to communicate and work together properly. In the former case, the user would most likely use an oscilloscope to debug the physical layer of the protocol. Parametric measurements such as rise and fall time, setup and hold times, and analyzing voltage levels could be made on signals in the system, such as the clock and data lines. For the latter problem, the designer may want to look at functional and integration issues within the system, which may require analyzing relative timing and data content on the bus.

Debugging problems like these in today's serial bus designs can be quite a challenge using traditional methods. A common method for debugging these systems has been to use a logic analyzer combined with an oscilloscope. However, triggering on a serial bus transition of interest can be difficult because there is no time reference to all of the data since it is read sequentially bit-by-bit. In the past, debugging a parallel bus with a logic analyzer was fairly straightforward by setting up a pattern or state trigger to find the interaction of interest.

However, setting up a logic analyzer to trigger on content within a long serial data stream is another matter. To trigger the logic analyzer on a serial pattern within a protocol requires the user to create a state machine that looks for the desired bit pattern or frame in the protocol. Unfortunately, most logic analyzer's state machines are usually only 16 levels deep, which does not meet the necessary depth to look for a problem in a long serial stream of data.

This solution also would require a lengthy process of measurement setups, which would probably result in a significant amount of user frustration. If the user needs to make parametric types of measurements on the system, correlating the logic analyzer with an oscilloscope would be even more time consuming. It would also require deep memory records on both instruments to view the long serial streams of data. With demanding schedules and project deadlines, most designers would agree that better techniques and tools are necessary for debugging designs that include serial bus technologies.

To meet and beat these challenges, Agilent has introduced a new method for debugging serial bus interfaces using a Mixed-Signal Oscilloscope (MSO) with specially designed triggering capabilities for serial protocols. These features solve the difficult

problem of triggering on the specific protocol conditions with a logic analyzer and oscilloscope. The Agilent MSO automatically finds the desired pattern in the long serial stream without the chore of creating a complicated state machine in a logic analyzer. The MSO is a single instrument with 16 digital timing channels and 2 analog scope channels with bandwidths up to 500 MHz. In addition, the MSO has very deep memory acquisition records using Agilent MegaZoom technology. These triggering features are easy to set up and can reduce the time you currently spend in debugging problems in embedded systems that utilize serial bus communications.

The serial bus triggering features in the MSO can trigger on serial buses with a synchronous clock, such as the I²C and SPI buses that have separate clock and data lines. In addition, the Agilent MSO is also able to establish a trigger on serial buses that have an embedded clock within the data stream, such as CAN and USB. These powerful new triggering features make it easy to correlate the sequential data and timing on long streams of data.

With up to 8 Mbytes of MegaZoom deep memory, the Agilent MSO can easily and quickly capture and analyze long serial streams. With one instrument, MegaZoom deep memory gives you the ability to look at the fast digital signals

Debugging Serial Bus Systems with a Mixed-Signal Oscilloscope (continued)

and correlate those with slow analog signals on long serial data streams. Also, the MSO's sixteen digital and two analog channels of acquisition are automatically time correlated. The dilemma of having to trigger twice to get a long time capture or to see detailed resolution is solved with MegaZoom deep memory.

Figure 1 shows an example of a microcontroller-based design that is used to control and monitor devices around the home. The microcontroller communicates with an RF transceiver, an RS232 bridge, an EEPROM, a keypad, and a display over the SPI bus. The MSO is the perfect debug tool for this design. With the combination of analog and digital channels, the user can correlate activity on the serial bus with what is

taking place in other parts of the system. This makes it easier to debug the source of a serial bus problem, such as a missing acknowledge, handshake, or an unintended packet loss. Additionally, the triggering features give the ability to look at the problems in real time instead of capturing the data and then using post processing to view the data record. This way the user can be sure that the signals being viewed are accurate representations of the current timing relationships in the system.

Many designs incorporate more than one type of serial interface for communication. For example, a design may use an I²C bus to communicate locally to an EEPROM and then another device may use a SPI bus to communi-

cate with other peripherals in the design. The entire design may then connect to an external network via USB or CAN. Having one instrument to debug many parts of a system can reduce debug time, cost, and frustration.

Using an Agilent MSO with MegaZoom deep memory and protocol-specific triggering solves the new challenge of finding and viewing problems within a long stream of serial data in today's embedded designs with serial buses. This application note describes the Agilent MSO serial protocol triggering features including I²C, SPI, CAN and USB, and how these features make debugging microcontroller and DSP-based designs easier and more efficient than ever before.

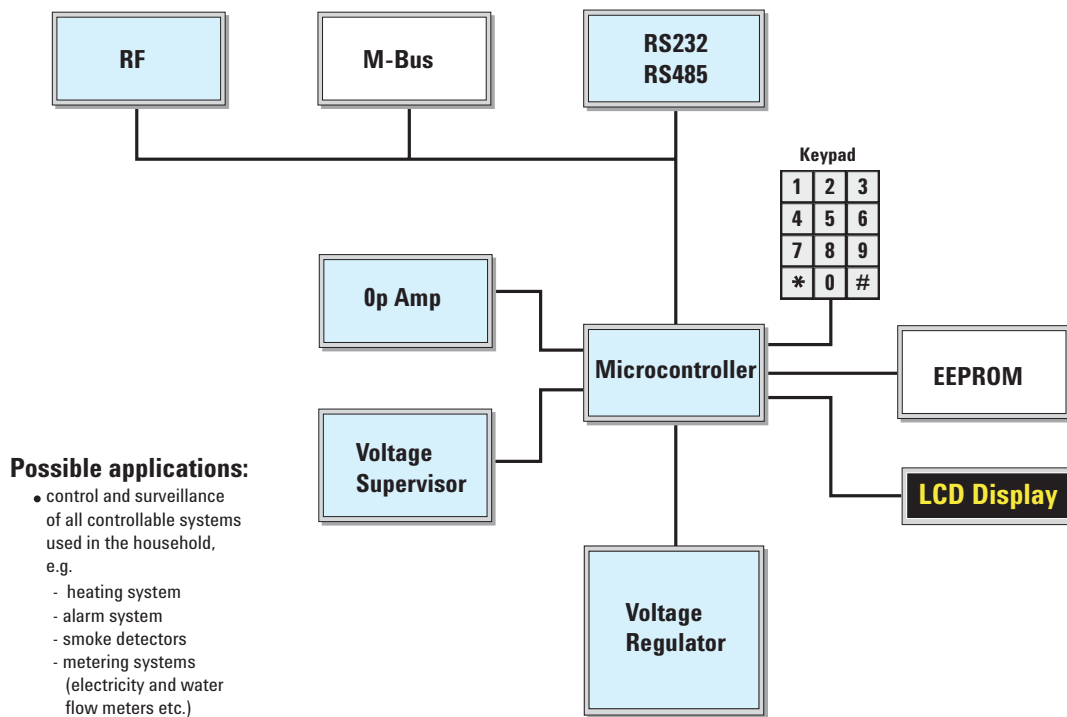

Figure 1. Example of a microcontroller-based design used to monitor and control devices in the home. The microcontroller uses the SPI bus to communicate with an RF transceiver, an RS232 bridge, an EEPROM, a keypad, and display

Inter-Integrated Circuit (I²C) Introduction

Philips originally developed the I²C (Inter-Integrated Circuit) bus for communication between devices inside of a TV set. Today, I²C is used in a broad range of applications for efficient inter-IC control and is supported by most semiconductor vendors. The I²C bus consists of a simple bi-directional two-wire bus with two signal lines, SCL (serial clock) and SDA (serial data). All I²C bus compatible devices have an on-chip interface that allows them to communicate directly with each other. Most I²C devices operate at speeds up to 400 Kbps, with some going into the low megahertz range.

The protocol is well defined and has a built in addressing scheme so there is no need for chip select

or logic controls. This makes it an inexpensive and simple solution to link many devices of an embedded design together. When it was first introduced, the I²C bus protocol used 7 bits for addressing. To accommodate the higher demand for more address space the bus now allows for 10-bit addressing and speeds up to 3.4 MHz yet remains backward compatible. Because of its low cost, it is widely used in many products, including cell phones, audio/video instruments, medical equipment, and industrial applications. In fact, there are hundreds of I²C compatible devices available today. Examples of simple I²C compatible devices found in embedded systems include EEPROMs, thermal sensors, and real-time clocks.

The I²C bus physically consists of two active signals and a ground connection. The signals SDA and SCL are both bi-directional. Every component connected to the bus has its own unique address, whether it is a CPU, an LCD driver, or an EEPROM. Each of these chips can act as a receiver and/or transmitter depending on their function. In addition, there may be one or more bus masters. The device that initiates data transfer on the bus is considered the bus master and all the others are bus slaves. Masters are generally microcontrollers, microprocessors, or DSPs. Figure 2 shows an example of an embedded system with an I²C bus.

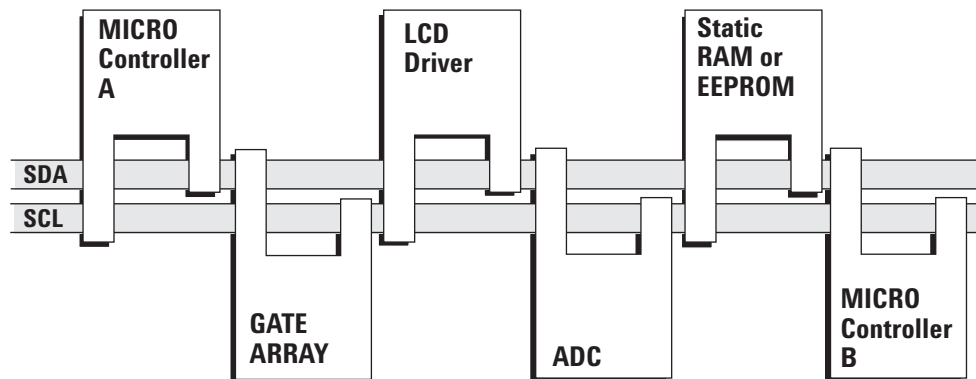

Figure 2. Example of an I²C bus system. The I²C bus consists of two active signals, SDA and SCL. Every component on the bus has its own unique address.

Debugging an I²C Bus System with the MSO Trigger Features

Using a conventional oscilloscope to debug and correlate data and timing in a long serial stream can be difficult and time consuming. A typical problem could be a microcontroller requesting information from a device, such as an LCD controller, and then not receiving any information back from the slave device. Debugging this problem with a conventional scope would require the user to digitize a long data record using either an edge or pattern trigger. The user would then need to scroll through the individual data frames one-by-one to search for the particular problem. Using this technique would be very time consuming.

Using an MSO with I²C triggering features and deep memory is a perfect solution for debugging problems with devices on an I²C bus. The 2 analog channels along with 16 digital timing channels make it possible to probe the two signals of the bus along with other signals, such as the data and address lines of an EEPROM, to see where the problems are really occurring in the system. With these features it is easy to trigger and set up the address and data conditions to debug the common I²C bus conditions, which could include a problem in the system behavior or on a specific I²C frame.

I²C Trigger Features

Setting up the I²C triggering features is simple. All of these features are accessed through the easy-to-use interface of the MSO. After assigning the data (SDA) and clock (SCL) to specific scope channels, the user can then select the I²C serial triggering options, as shown in Figure 3. The two lines of the bus can be probed by either the digital timing channels or the analog scope channels and are automatically labeled on the screen.

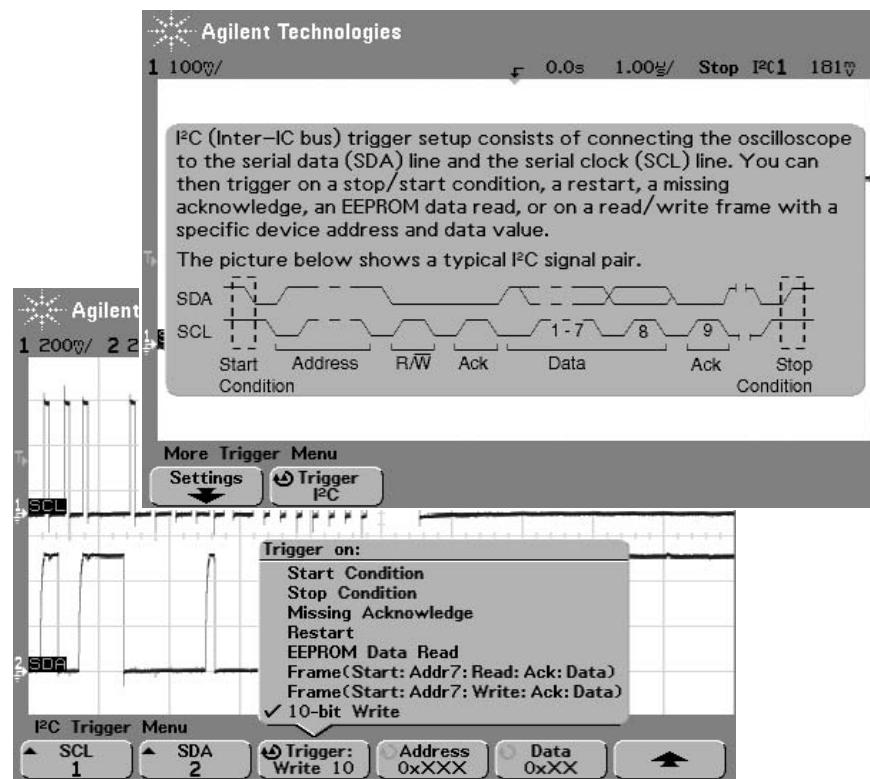

Figure 3. Setting up I²C triggering on the Mixed-Signal Oscilloscope. The MSO quick help screen gives detailed instructions on how to use the I²C triggering features.

Debugging an I²C Bus System with the MSO Trigger Features (continued)

Content Triggering: Read or Write Frame of a Specific Address and Data Value

In a typical I²C frame, there is a start condition, a control byte that configures the particular slave to be read from or written to, a valid acknowledge clock pulse, and then other bytes of the transferred data. The MSO can be easily configured to trigger on the address byte and/or data of the control byte or the secondary byte.

This is a powerful triggering feature that allows the user to look within the I²C frame to trigger when a device at a particular address is written to or read from with a data value. For example, in Figure 4 the MSO triggers when a microcontroller writes the data value 41 hex to a keypad at address 50 hex on the I²C bus. This feature can be very useful to find errors in software routines that write incorrect data to a device.

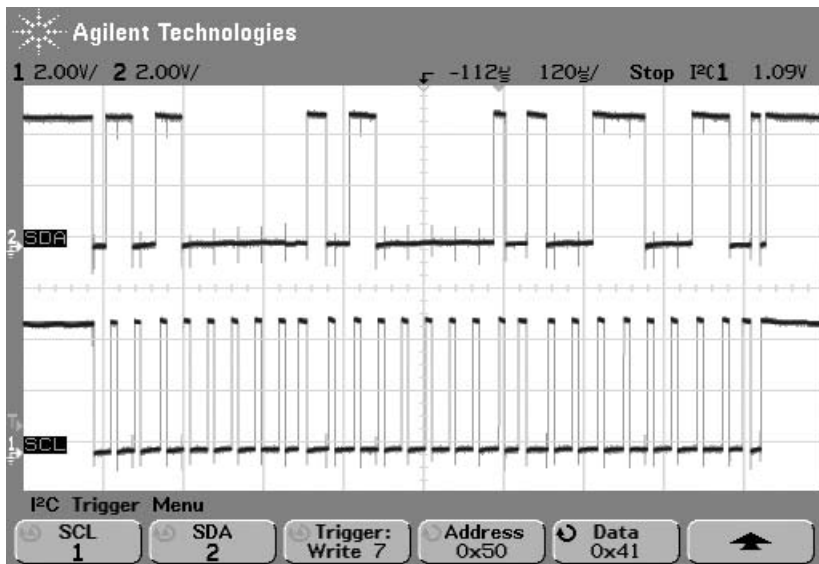

Figure 4. I²C trigger on a Write Frame with Address and Data. This powerful triggering feature allows the user to look within the I²C frame to trigger when a device at a particular address is written to or read from with a data value.

EEPROM Data Read Trigger

In the I²C protocol, EEPROMs have a predetermined address on the bus in the form of 1010xxx binary. The EEPROM Data Read Trigger looks for an address matching this pattern on the SDA line, followed by a read bit and then an acknowledge bit. When the data matches the qualified condition set by the user, the MSO triggers on the acknowledge clock edge after the data is sent.

The MSO can trigger on a “current address read” cycle, a “random read” cycle, or on any data byte within a “sequential read” cycle. The MSO trigger hardware looks for the appropriate control byte first, followed by any data byte that meets the user-specified qualifications. These qualifications include less than, greater than equal, not equal, and don’t care.

For example, suppose a microcontroller stores calibration data from a temperature sensor in memory to use at a later time in a program. But when the data is read back, it is corrupt and causes the sensor to perform incorrectly. This trigger feature of the MSO would give the user a quick and easy way to track and debug data being read from an EEPROM in the system.

Debugging an I²C Bus System with the MSO Trigger Features (continued)

I²C Bus Start and Stop Trigger

Using the I²C protocol, a start condition must be issued before any transaction on the bus occurs. The start condition acts as a signal to all connected devices that a message is about to be transmitted on the bus. As a result, all connected chips will listen to the bus. After a message is sent, a stop condition occurs. This is the signal for all devices on the bus that the bus is free again. The chip accessed during the message will then process the received information.

It could be very difficult to find a start or stop condition on the I²C bus using edge triggering with a traditional scope; there could be hundreds of pulses to scroll through. Using the I²C start con-

dition triggering, as shown in Figure 5, the MSO triggers when it detects a start condition by looking for a high to low transition of the SDA (data) line while the SCL (clock) line is high.

I²C Bus Re-Start Trigger

Within a single message there can be multiple Start conditions in a frame. The MSO with I²C triggering is able to find a restart within a frame after the start condition occurs.

I²C Bus Missing Acknowledge Trigger

After each byte transfer, an acknowledge is sent. This occurs when the SDA line is pulled high and the SCL line is pulsed. If a device never sends an acknowl-

edge command, it can cause the bus to hang up and it could be difficult to find the actual problem. Is it the microcontroller not sending the correct address information or is the slave device not responding? Setting up the MSO to trigger on a missing acknowledge can help isolate a problem such as this very quickly. It will find a missing acknowledge event anywhere in an address/control byte or data byte of any size I²C frame.

10 Bit Write Trigger

Ten-bit addressing allows the use of up to 1024 addresses to prevent problems with the allocation of slave addresses as the number of I²C devices continues to expand. The MSO triggers on a 10-bit write to an address in a frame if all data in the pattern matches.

The MSO trigger features, designed specifically for the I²C protocol, make debugging I²C buses easier than ever before and allow the user to find problems in real time whether they are problems within the protocol design itself or problems with devices in a system.

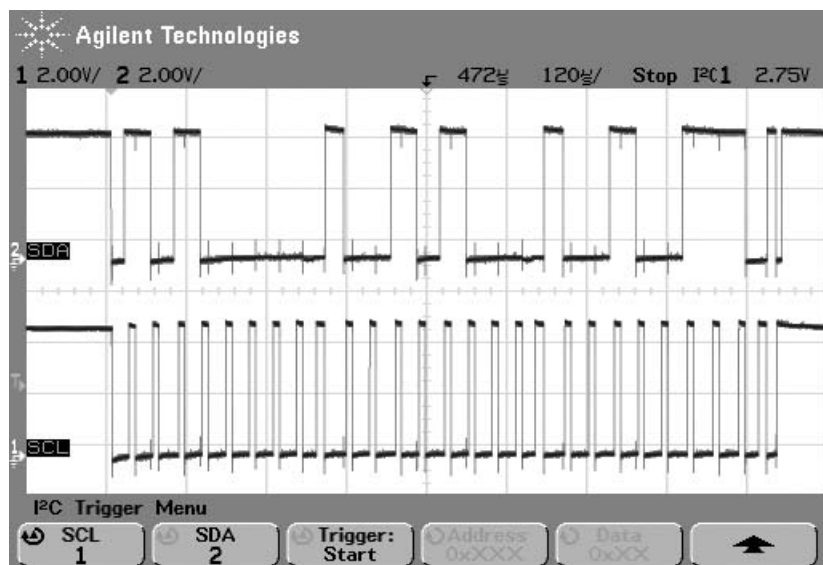

Figure 5. Start of Frame trigger. The MSO triggers when it detects a start condition by looking for a high to low transition of the SDA (data) line while the SCL (clock) line is high.

Serial Peripheral Interface (SPI) Introduction

The Serial Peripheral Interface, SPI, is a serial bus standard originally introduced by Motorola with interfaces available on many popular communication processors and microcontrollers. Like I²C, SPI provides good support for communication with slow peripheral devices that are accessed intermittently, such as EEPROMs and real-time clocks. However, SPI is better suited than I²C for applications that are thought of as data streams because of its high bandwidth (in the tens of megahertz), whereas I²C devices read and write to addressed locations in a slave device. An example of a data stream application is the data communication between microprocessors, microcontrollers, A/D converters, D/A converters, or DSPs.

Devices on a SPI bus communicate using a master/slave relationship, in which the master, usually the microcontroller, initiates the data transfer. When the master generates a clock and selects a slave device, data can be transferred in either or both directions at the same time (called full-duplex mode). The protocol helps the device to determine if the data is a valid signal or not, depending on bits set in the frame.

The SPI bus consists of two data lines and two control lines. The data lines are MOSI (master data output / slave data input) and MISO (master data input / slave

data output). The control lines include SCLK (serial clock), and SS (slave select). The master may transmit data at a variety of data rates. The serial clock control line is driven by the master and controls the flow of the data bits and cycles once for each bit transmitted. The slave select control line allows slaves to be turned on and off with hardware control. Unlike I²C, the SPI protocol does not have a start of frame; the chip select or slave select (SS) going high or low (depending on the device) frames the data. Figure 6 shows a block diagram of a web phone, which is an example of a multi-slave system.

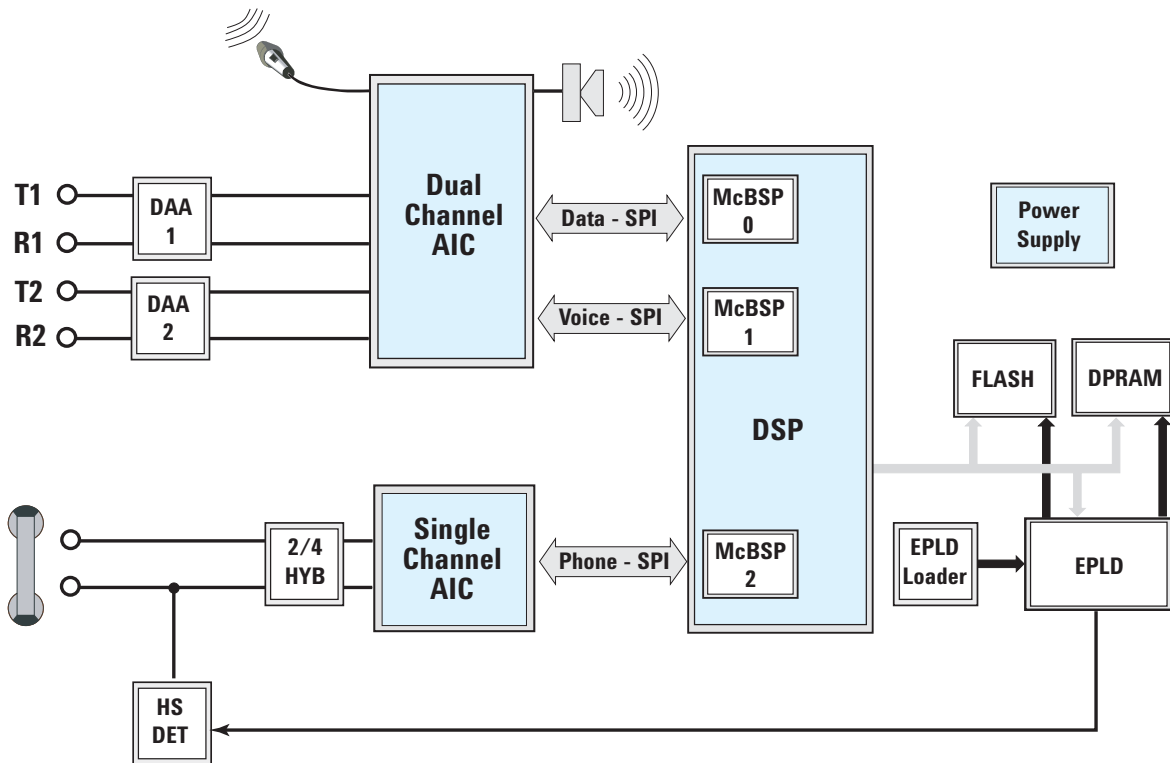

Figure 6. Web Phone Block Diagram; example of a multi-slave SPI bus, DSP-based system.

Debugging an SPI Bus System with the MSO Triggering Features

Because SPI does not have a formal standard, there are many different types of implementations. Common debug problems in SPI systems involve configuring the clock rate for the controller as well as the phase and polarity for how each peripheral clocks data in and out. For example, in the web phone device shown in Figure 7, some devices may or may not clock data in and out using the same polarity and phase of the clock. Because of this, there could be difficulties configuring the devices on the bus.

An MSO with SPI triggering features and deep memory is a great tool for debugging long serial streams, where configuration errors may cause problems in the

system. In the previous web phone design, MegaZoom deep memory allows the user to correlate audio events, in the 20 kHz range, with DSP digital events, in the 10 MHz range, all in the same acquisition. The user can connect to the clock, data (either MISO or MOSI) and chip select framing (SS) signals in the target system. As shown in Figure 7, the 2 analog channels can monitor the data and clock while the 16 digital timing channels can monitor the chip select lines attached to the peripheral devices.

The MSO triggers on a serial data pattern during a framing period. The clock slope can be set to either a falling or rising edge. The serial data string can be specified

to be from 4 to 32 bits long, and the individual bit values in the frame can be assigned to either a L, H, or X (don't care) condition. Making things even easier, the CS, Clock and Data labels for the source channels are automatically set up on the screen.

The user must select a framing signal for the MSO serial trigger hardware to detect. This framing signal can be a high chip select (SCS) or a low chip select (\sim CS). Also, the MSO can generate its own framing signal after a user-specified time of clock inactivity. The MSO requires a setup time of 50 ns from the framing signal going true to the first active clock edge. The data setup and hold times are 10 ns and 5 ns, respectively. The MSO will trigger on the Nth clock edge (from 4 to 32) if the specified data pattern is true.

This is a very elegant and easy-to-use solution, especially compared to previous methods using a logic analyzer and an oscilloscope, which don't work well for debugging serial bus systems. Using an MSO, the user does not have to create a state machine by hand to find the desired pattern in a serial stream of data, nor does the user have to correlate measurements with an oscilloscope. The MSO does the work to find the pattern of interest, all in a few easy steps. Debugging an SPI bus would traditionally have been very difficult to perform, but the Agilent MSO has just the right features to save design engineers time debugging problems in order to spend more time designing.

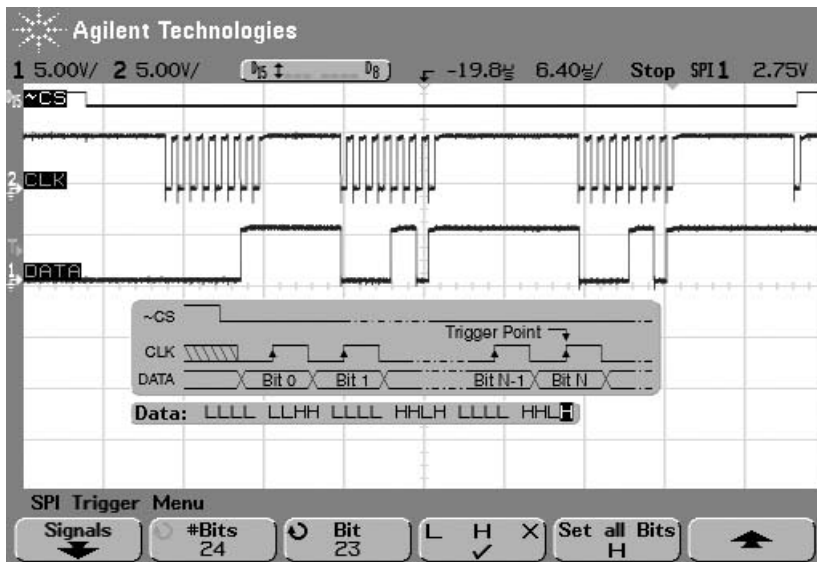

Figure 7. Setting up and triggering on SPI signals. The MSO will trigger on the Nth clock edge (from 4 to 32) if the specified data pattern is true.

Controller Area Network (CAN) Introduction (continued)

Low-cost CAN controllers, micro-controllers with embedded CAN controllers, and interface devices are available as off-the-shelf parts from many semiconductor manufacturers. Figure 9 shows a typical CAN node that includes a microcontroller with a dedicated CAN controller using an external address bus. Some controllers are designed to interface either as parallel devices on the address

bus or by using another serial bus interface, such as SPI. The CAN transceiver has both a transmit and a receive side, so that it can write to and read from the bus simultaneously. An example of a CAN node is shown in Figure 9. This could be a system node for a power window, engine monitoring, or suspension control in an automobile.

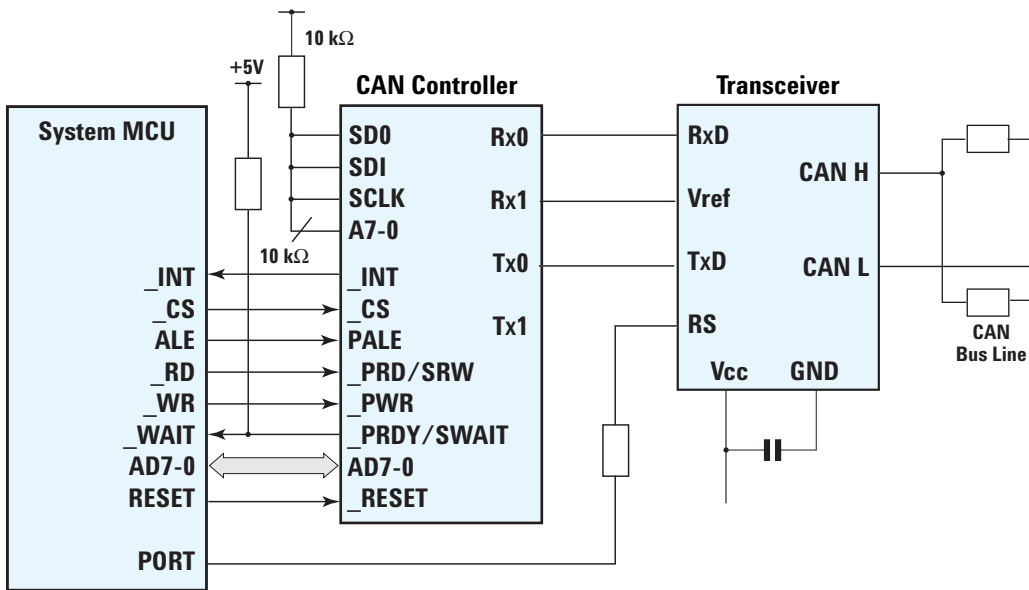

Figure 9. Example CAN node.

Debugging a CAN Bus System with the MSO Triggering Features

There are four different types of communication on the CAN bus. A message frame contains the application data, a remote frame requests data from the network, an error frame reports errors to each node, and an overload frame delays transmission of a CAN frame if the receiver circuitry of a node is not ready. The MSO CAN triggering modes provide the ability to synchronize to any message frame, remote transfer request frame, or overload frame.

Since a frame of information is usually a known place in the operation of a CAN node, this allows for a synchronous look at other signals on that particular CAN node. Shown in Figure 10 is the MSO Quick Help description

of the CAN standard frame format. At the beginning of the frame is the Start Of Frame (SOF) bit. The MSO triggering capabilities allow the user to synchronize the scope acquisition to the start of a CAN frame, permitting oscilloscope user to look at other operations and signals in their design that are time-correlated to the CAN bus traffic. These triggering features operate on either the CAN 2.0B format with a 29-bit identifier or 2.0A with an 11-bit identifier.

One example of how these features can be useful is to debug automotive applications in real time. For instance, a message that causes the engine to start could also cause noise from the engine

to be induced into the electronic control system. This noise would be synchronous to the Start of Frame and could be difficult to isolate. Using edge triggering to find a problem like this would require the user to scroll through many pulses in a waveform and could be very difficult to synchronize and correlate to the data. But with the SOF triggering capability, this activity is synchronous to the trigger of the MSO. The user can probe using the analog channels to see the noisy components of the signal. With MegaZoom deep memory, the user can then look back in time in the frame so that the problem can easily be isolated and analyzed to find the cause of the noise problem.

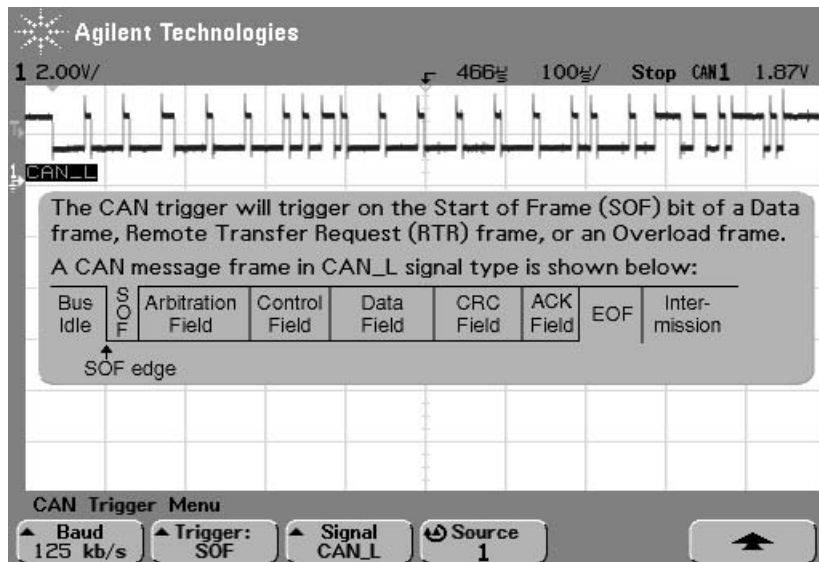

Figure 10. CAN trigger Quick Help description. The MSO triggering capabilities allow the user to synchronize the scope acquisition to the start of a CAN frame.

Debugging a CAN Bus System with the MSO Triggering Features (continued)

CAN Trigger Features

With an MSO, the user can probe a CAN signal with any of the 2 analog or 16 digital timing channels or a combination of channels. When using only one of the channels to synchronize to the CAN frame, 17 other channels remain to provide a broader view into the design. These 17 channels, coupled with Agilent Technologies MegaZoom deep memory, give an unparalleled breadth and depth of insight into complex embedded CAN node designs and interactions.

Specify Baud Rate

To synchronize to the bus traffic correctly, the user can specify the Baud Rate of the system from 10 kbps up to 1 Mbps. The baud rates allowed follow the CiA (CAN in Automation) trade associations recommended baud rates.

Trigger Signals Include CAN_H, CAN_L, Rx, or Tx

The user can also specify the CAN-based signal to monitor. It can be either of the differential CAN signals, CAN_H or CAN_L. These are useful for monitoring the bus itself, especially when they are the only signals the user has access to. Using an MSO, it can also be useful to look at parametric information about these signals, including noise spikes, ringing, and timing measurements. Because these are differential signals designed for a noisy environment, noise spikes may cause false triggers to occur while looking at a CAN_H or CAN_L signal. To counter this, use a differential probe such as the Agilent N2772A 20 MHz differential probe, to look at the actual noise-immune differential signal. A signal type selection, titled 'Differential' in the menu system, is available for this case.

The user can also probe the Rx and Tx on the digital side transceiver signals. The Rx signal gives a view of all of the traffic on the bus and is included for ease of access. The Rx signal should not be susceptible to noise/level drift on the physical bus line CAN_H and CAN_L. The Tx line provides more information because it has activity on it only when the source node is sending a message on the bus. Probing this line can help isolate the traffic to a particular node.

Real-time triggering combined with MegaZoom deep memory, 2 analog and 16 timing channels makes the MSO a great tool for debugging CAN systems. The MSO's CAN protocol trigger features help the user to easily synchronize to the data frames of interest, making it easier to find problems in automotive and industrial designs. For communications within an automotive electronic module, an SPI interface is commonly used. Because the MSO has the ability to trigger on multiple types of serial buses, it is an invaluable measurement instrument for debugging CAN system in not only automotive applications but also in many industrial control systems.

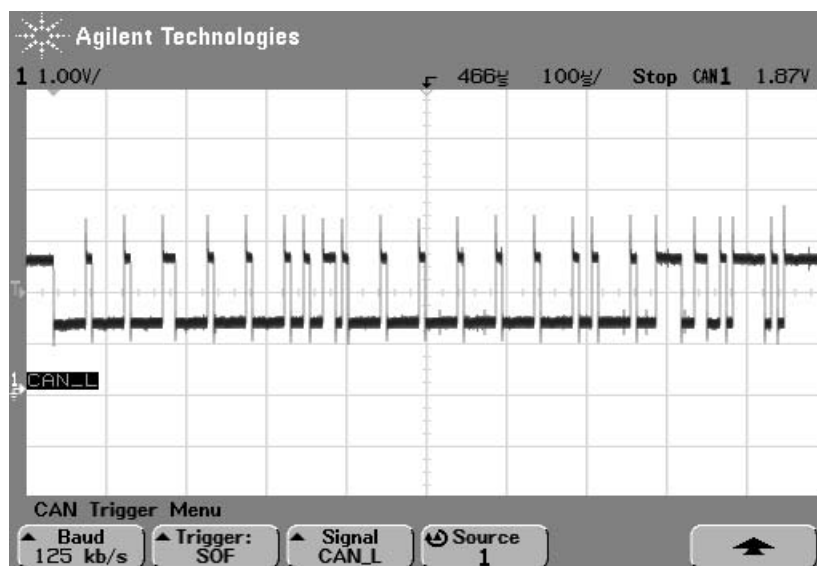

Figure 11. The user can specify the CAN-based signal to monitor. Shown here is a CAN-L signal.

Universal Serial Bus (USB) Introduction

The Universal Serial Bus (USB) provides a high data rate and an easy connection from a PC to a wide variety of multimedia and networked USB peripheral devices. The USB port of a PC enables a user to add peripherals to the system without having to open the system chassis. Additionally, USB allows users to run numerous devices, such as printers, scanners, digital cameras, and speakers, from a single PC.

Peripherals such as hubs and hosts operate at full speed (12 Mb/s) or low speed (1.5 Mb/s). These speeds are adequate for devices such as mice or keyboards, but would be very limiting and not usable for next-generation imaging and video devices, such as

high-resolution printers and scanners, video-conferencing cameras, and read/write (R/W) DVD drives. For these types of devices, high-speed USB increases data throughput by a factor of 40 over full speed USB to 480 Mb/s. The USB 2.0 version incorporates low, full, and high speeds and is a backward compatible extension of USB 1.1 using the same cables, connectors, and software interfaces.

USB also supports plug-and-play capability for automatic device detection and installation. USB has become a standard in the PC industry; virtually every new PC today has one or more USB ports. Figure 12 shows a typical USB system with a PC connected to many peripherals through a hub.

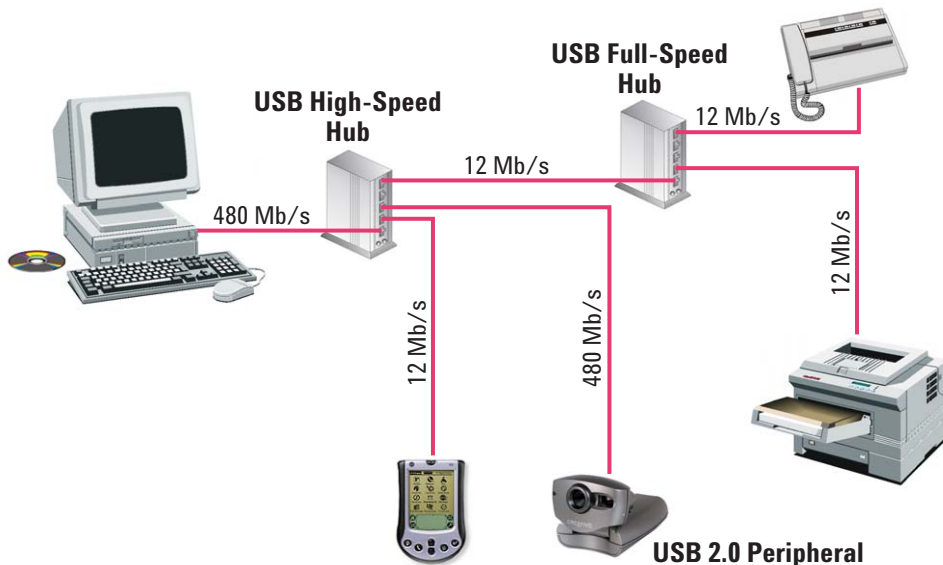

Figure 12. Example USB system.

Debugging a USB System with the MSO Triggering Features

Debugging the physical layer of a USB device is dependent on the visibility into the system. For instance, a USB keyboard controller might consist of a micro-controller, an EEPROM, and other devices encapsulated into a single package. In this case, the user only has access to the USB interface line to the keyboard and cannot probe the internal devices in the controller unit. If pressing the CAPS LOCK key does not turn on the LED on the keyboard, there could be a number of potential sources of the problem. These include but are not limited to a problem in a software setup, a device failure, or a protocol error. To view dependencies and setup conditions it is important for the test equipment to isolate the USB packets in order to find where problems in the system may be occurring.

The USB serial protocol has a host-centric bus, meaning the host initiates all transactions. An example packet is shown in Figure 13 in the USB QuickHelp description of the MSO. The first packet generated by the host describes the information to follow and whether the data transaction will be a read or write. The next packet is usually a data packet carrying the payload and is followed by a handshaking packet reporting if the data or token was received successfully, or if the endpoint device is not able to accept data.

The USB packet fields include a Sync field, a Packet ID field, an Address field, an Endpoint field, a Cyclic Redundancy Check field, and an End of Packet field. All

packets must start with a sync field to synchronize the clock of the receiver with that of the transmitter. The Packet ID field is used to identify the type of packet that is being sent, and the address field specifies which device the packet is directed towards. Cyclic Redundancy Checks are performed on the data within the packet payload and following all of these fields is the End of Packet field.

The USB serial bus is a four-wire system with signals including VBUS, D-, D+ and Ground. D- and D+ are differential signals and are the primary carriers of the information. The VBUS signal supplies power to devices that derive their primary power from the host or hub.

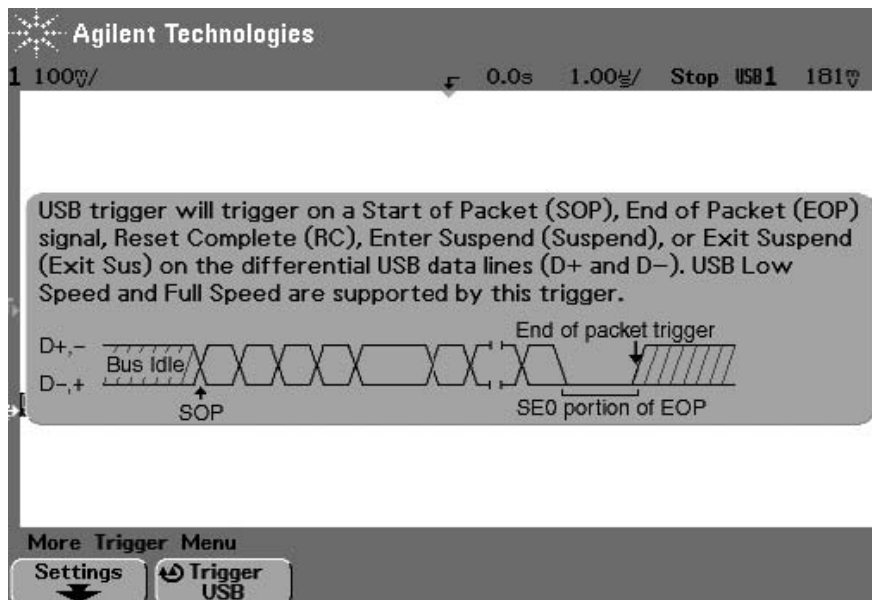

Figure 13. MSO USB QuickHelp description. The Agilent MSO can trigger on both low- and full-speed USB.

Debugging a USB System with Agilent MSO Triggering Features (continued)

USB Trigger Features

In the USB trigger mode, the Agilent MSO can trigger on both low- and full-speed USB. The user can probe the differential lines, D+ and D-, with any of the 2 analog lines or 16 digital timing lines using the following trigger modes:

Start of Packet (SOP), End of Packet (EOP)

The SOP packet consists of an 11-bit frame number. The Agilent MSO triggers at the Sync bit at the beginning of the packet.

The End of Packet is a field within a USB packet and is signaled by a Single Ended Zero (SE0) for a specified number of bit times. The Agilent MSO triggers at the end of the SE0 portion of the End of Packet.

Enter Suspend, Exit Suspend

A USB device will enter suspend when there is no activity on the bus for greater than 3.0 ms. The MSO triggers when the bus is idle for greater than 3 ms. In the Exit Suspend trigger mode, the MSO triggers when exiting an idle state for greater than 10 ms in order to see the suspend/resume transition.

Reset Complete (RC)

In the Reset Complete trigger mode the MSO will trigger when a Single Ended Zero (SE0) is greater than 10 ms.

There are many instances where the USB trigger modes are useful for debugging the physical layer of the USB protocol. With these trigger modes, the user is able to synchronize to USB packets being communicated over a USB connection between a host and a USB peripheral device, making it easier to correlate relationships within the protocol to find problems in the system.

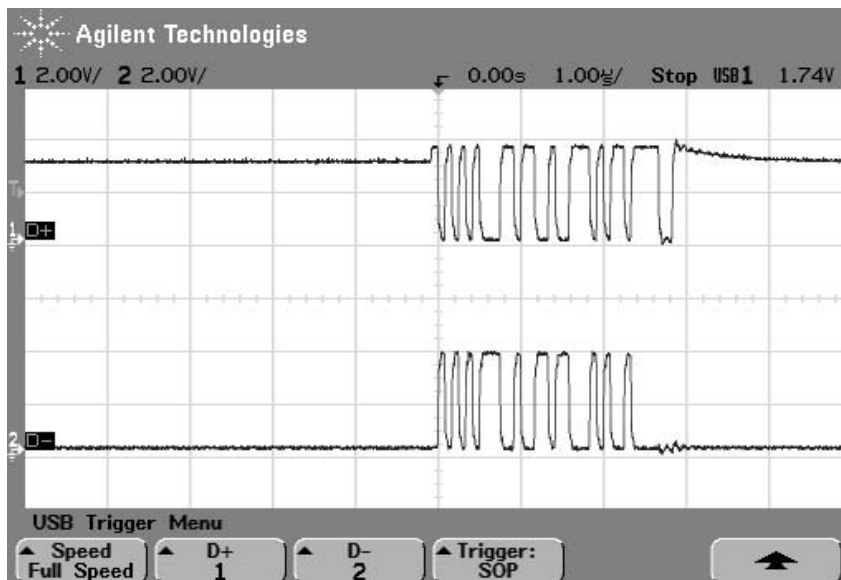

Figure 14. The Agilent MSO triggers at the sync bit at the beginning of the packet.

Summary

New technology trends bring with them new design and debug challenges. Agilent's Mixed-Signal Oscilloscope (MSO) provides an added dimension to solving problems when debugging microcontroller and DSP-based designs incorporating serial buses.

Agilent has solved the problems associated with debugging serial bus interfaces by providing a unique solution that uses a MSO with specially designed triggering capabilities to easily debug protocols and the interactions of devices on these buses. Having one easy-to-use instrument to debug many parts of a system can reduce debug time, cost, and frustration helping to get designs out the door and into production faster. The advantages of using an MSO include:

- The powerful serial triggering features allow for real time triggering to correlate timing relationships in microcontroller and/or DSP-based designs using I²C, SPI, CAN, or USB serial protocols.
- Serial protocol trigger features are easy to use and set up; there is no need to design a complicated state machine in a logic analyzer to debug serial protocols.
- Agilent's MSO has 2 analog channels and 16 digital channels to make parametric, timing, and functional measurements all in one instrument.
- With up to 8 Megabytes of MegaZoom deep memory, the MSO can easily and quickly capture and analyze long serial streams and correlate fast digital signals with slow analog signals, all in one acquisition.
- A revolutionary ultra-responsive, high-definition display reveals subtle waveform details that most digital scopes can't show.
- QuickHelp instructions (in 11 languages) give details on how to use these powerful capabilities.

The unique 2+16-channel Mixed-Signal Oscilloscope (MSO) models and the traditional 2- and 4-channel oscilloscope models are optimized with just the right capabilities to verify and debug microcontroller and DSP-based designs incorporating serial buses. This combination of capabilities is tailored to give the measurement power needed to deliver higher quality products to market faster.



www.agilent.com/find/emailupdates

Get the latest information on the products and applications you select.



www.agilent.com/find/quick

Quickly choose and use your test equipment solutions with confidence.



www.agilent.com/find/open

Agilent Open simplifies the process of connecting and programming test systems to help engineers design, validate and manufacture electronic products. Agilent offers open connectivity for a broad range of system-ready instruments, open industry software, PC-standard I/O and global support, which are combined to more easily integrate test system development.

Microsoft® and Windows® are U.S. registered trademarks of Microsoft Corporation.

Pentium® is a U.S. registered trademark of Intel Corporation.

Remove all doubt

Our repair and calibration services will get your equipment back to you, performing like new, when promised. You will get full value out of your Agilent equipment throughout its lifetime. Your equipment will be serviced by Agilent-trained technicians using the latest factory calibration procedures, automated repair diagnostics and genuine parts. You will always have the utmost confidence in your measurements.

Agilent offers a wide range of additional expert test and measurement services for your equipment, including initial start-up assistance onsite education and training, as well as design, system integration, and project management.

For more information on repair and calibration services, go to

www.agilent.com/find/removealldoubt

www.agilent.com

For more information on Agilent Technologies' products, applications or services, please contact your local Agilent office. The complete list is available at:

www.agilent.com/find/contactus

Phone or Fax

United States:

(tel) 800 829 4444
(fax) 800 829 4433

Canada:

(tel) 877 894 4414
(fax) 800 746 4866

China:

(tel) 800 810 0189
(fax) 800 820 2816

Europe:

(tel) 31 20 547 2111

Japan:

(tel) (81) 426 56 7832
(fax) (81) 426 56 7840

Korea:

(tel) (080) 769 0800
(fax) (080) 769 0900

Latin America:

(tel) (305) 269 7500

Taiwan:

(tel) 0800 047 866
(fax) 0800 286 331

Other Asia Pacific Countries:

(tel) (65) 6375 8100
(fax) (65) 6755 0042
Email: tm_ap@agilent.com

Revised: 09/14/06

Product specifications and descriptions in this document subject to change without notice.

© Agilent Technologies, Inc. 2007
Printed in USA, September 12, 2007
5988-5997EN



Agilent Technologies